

VALVOLA DI RIEMPIMENTO A CARTUCCIA



Caratteristiche

TIPO	Grandezza nom.	Portata max. consigliata	Press. max.	Rapp. di sblocco	Press. max. di pilotaggio	Massa (Kg)
RC-100	DN-25	100 l/min.	350 bar	3.6:1	150 bar	0.55
RC-114	DN-32	170 l/min.		3.6:1		1
RC-112	DN-40	240 l/min.		3.9:1		2
RC-200	DN-50	360 l/min.		4.2:1		3.5
RC-212	DN-63	580 l/min.		4.5:1		6.5
RC-300	DN-80	810 l/min.		4.3:1		10.5
RC-400	DN-100	1210 l/min.				22.5

Descrizione

Sono valvole che consentono il preriempimento e lo scarico rapido dei cilindri nelle presse a compressione.
La costruzione a sede dell'otturatore garantisce la tenuta perfetta.

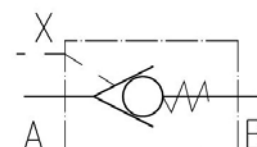

INSTALLAZIONE A BLOCCO (RC - ***/P)

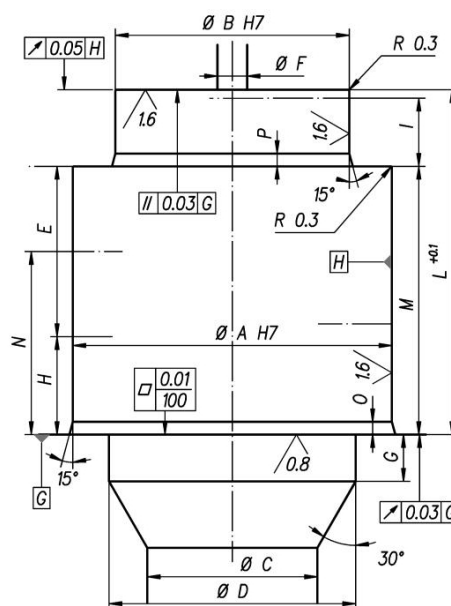
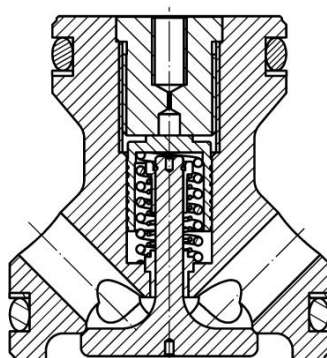
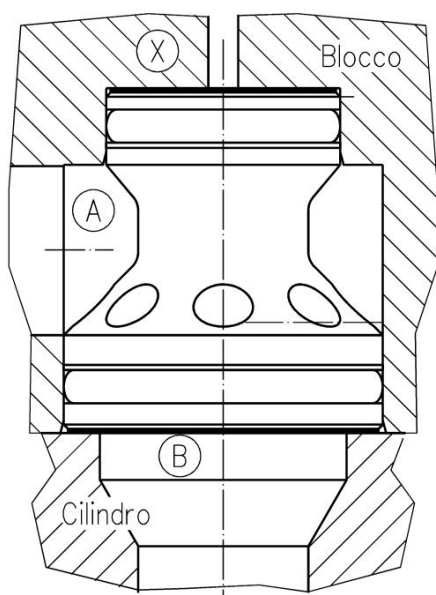

TIPO	DN	A H7	B H7	C	D	E	F	G	H	I	L	M	N	O	P
RC-100	25	43	37	25	36	25	7	7	30	13	70	56	43.5	2.5	2.5
RC-114	32	58	50	31	46	32	7	9	30	13	78	63	47	2.5	2.5
RC-112	40	75	55	40	58	40	7	11	26	16	81	63	43	3	3
RC-200	50	90	68	50	71	50	7	14	31	20	100	78	53	4	3
RC-212	63	120	90	63	90	60	7	16	32	23	114	89	59	4	4
RC-300	80	145	110	78.5	107	76	7	18	36	23	134	109	71	5	5
RC-400	100	180	135	95	132	93	7	30	60	30	180	148	101	8	8

VALVOLA DI RIEMPIMENTO A CARTUCCIA



INSTALLAZIONE SU CILINDRO (RC - ***/Z)

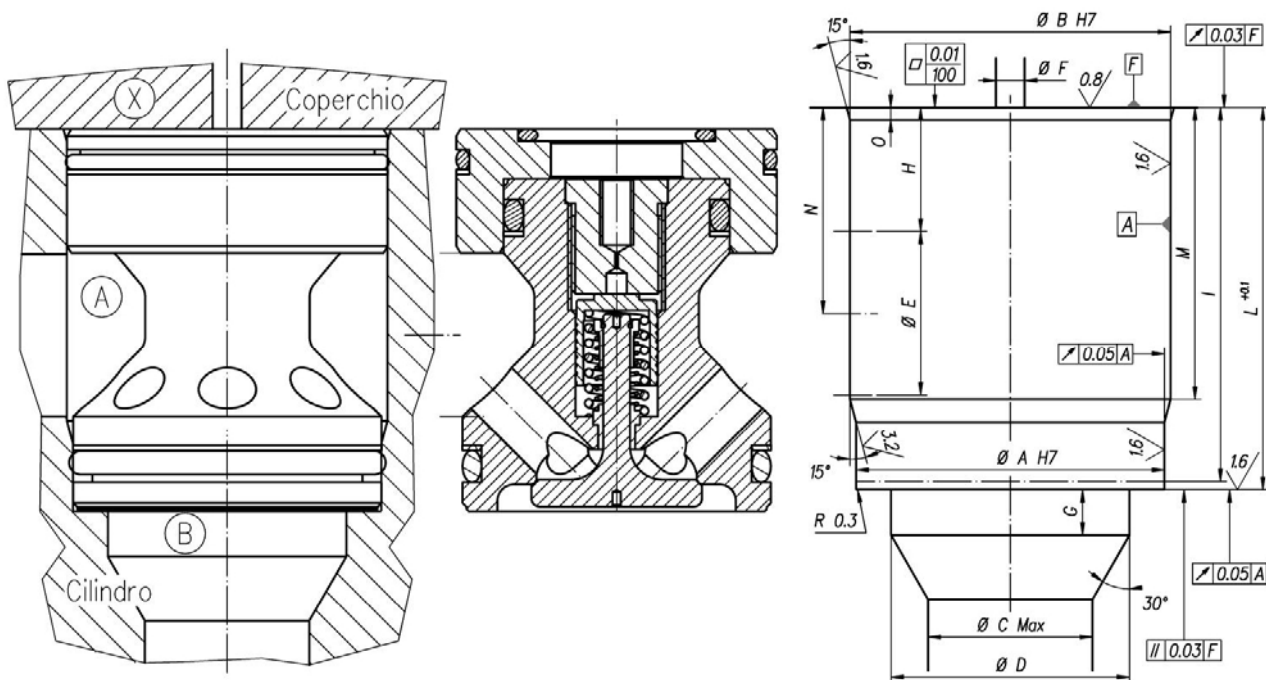

TIPO	DN	A H7	B H7	C	D	E	F	G	H	I	L	M	N	O
RC-100	25	43	45	25	36	25	7	7	27	83	85	60	41	2.5
RC-114	32	58	60	31	46	32	7	9	28	89.5	91.5	66	44	2.5
RC-112	40	75	78	40	58	40	7	11	30	91	93	71	50	3
RC-200	50	90	93	50	71	50	7	14	34	110	112	85	59	4
RC-212	63	120	123	63	90	60	7	16	40	128	130	101	71	4
RC-300	80	145	150	78.5	107	76	7	18	40	148	150	117	79	5
RC-400	100	180	185	95	132	100	7	30	50	188	200	152	101	8

Pressione differenziale in aspirazione e scarico in relazione alla portata

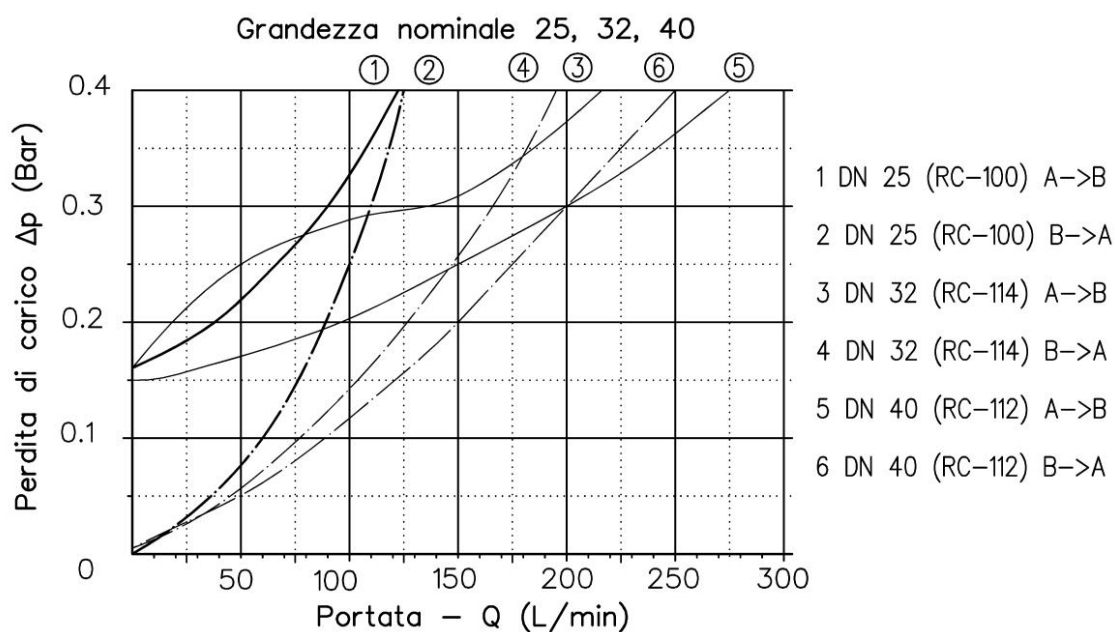



Pressione differenziale in aspirazione e scarico in relazione alla portata

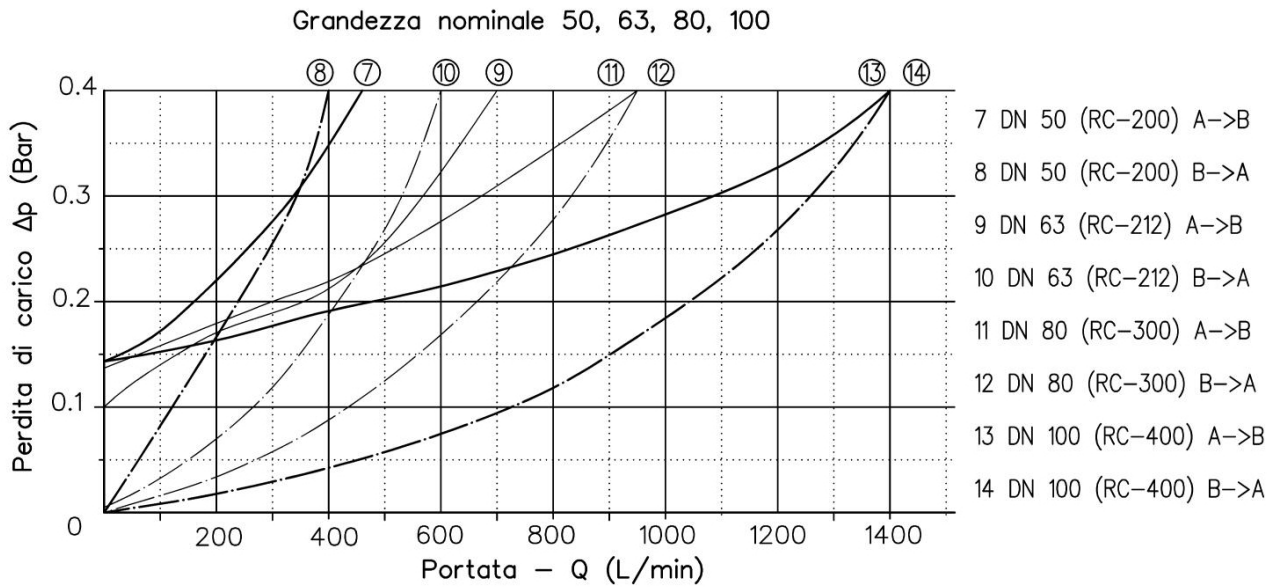

Norme di installazione

- Montaggio previsto in verticale sottobattente
- Fluido da utilizzare: olio idraulico a norme DIN 51524 con viscosità compresa tra 30 e 100 mm²/s (cSt) a 40°C
- Filtrazione richiesta del fluido impiegato 25μ
- Temperatura fluido idraulico: da -20° a +80°C

Ordinazione

