

# PISTON PRESSURE SWITCH type IP



## Characteristics

TYPE	PRESSURE SETTING RANGE	MAX WORKING PRESSURE	REPEATABILITY	WEIGHT
IP-035	6-35 bar	350 bar	<math>\pm 2\%</math> of setting	0.35 Kg.
IP-150	12-150 bar			
IP-250	15-250 bar	650 bar		
IP-350	30-350 bar			
IP-630	50-630 bar			

## Description

Piston operated, fixed differential, electro-hydraulic pressure switch equipped with electric contact in exchange.

When pre-set pressure is achieved, the piston actuates a microswitch. The setting adjustment is achieved by means of a grub screw (R).

## Dimensions

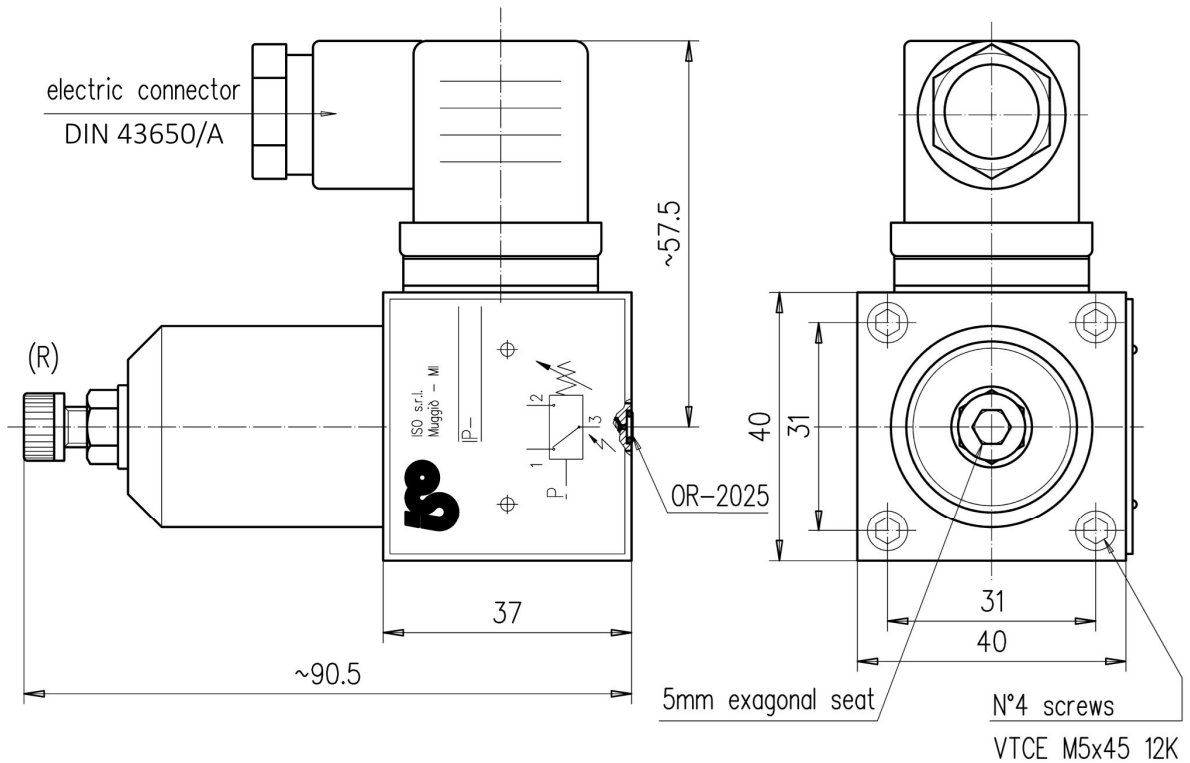

## Symbol

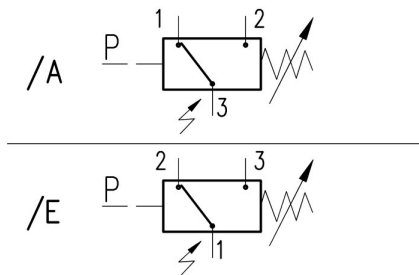

## Contacts

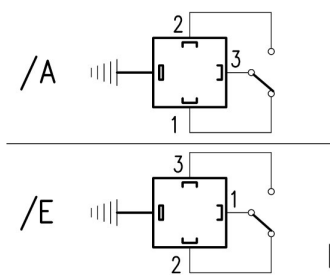

## Flange interface

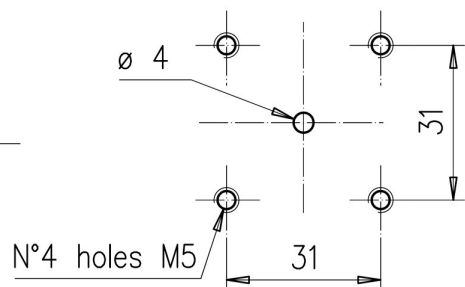

# PISTON PRESSURE SWITCH type IP



## Electric characteristics

Voltage (V)	125 AC	250 AC	30 DC	150 DC
Max current (Resistive load)	7 Amp.	5 Amp.	5 Amp.	0.2 Amp.
Max current (Inductive load) $\text{Cos } \varphi = 0.4$	4 Amp.	2 Amp.	3 Amp.	0.02 Amp.
Connection frequency	Max. 120 cycles/min			
Protection	IP-65			
Direct current with inductive load	It is suggested to provide an arching contact			
Contact resistance	15 m $\Omega$			

## Diagram

DIFFERENTIAL PRESSURE OF IP-35 PRESSURE SWITCH

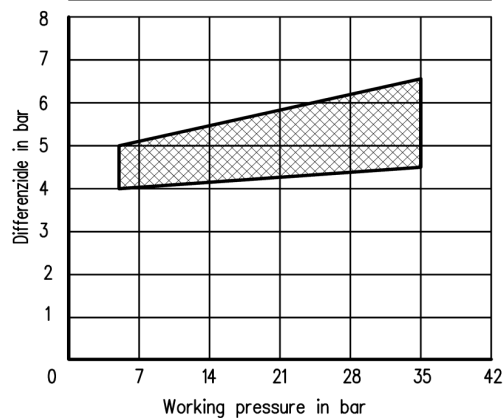

DIFFERENTIAL PRESSURE OF IP-150 PRESSURE SWITCH

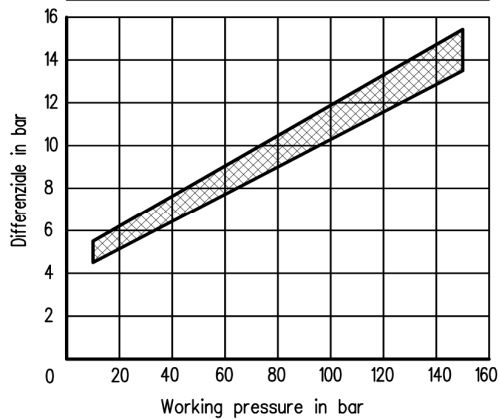

DIFFERENTIAL PRESSURE OF IP-250 PRESSURE SWITCH

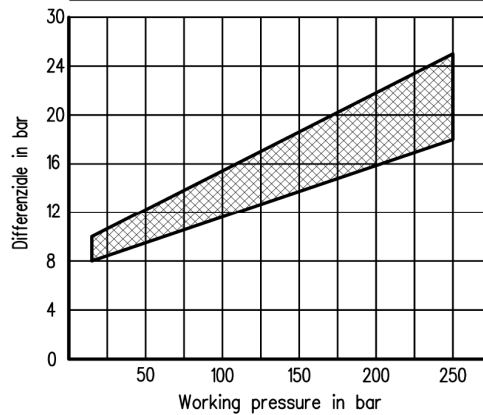

DIFFERENTIAL PRESSURE OF IP-350 PRESSURE SWITCH

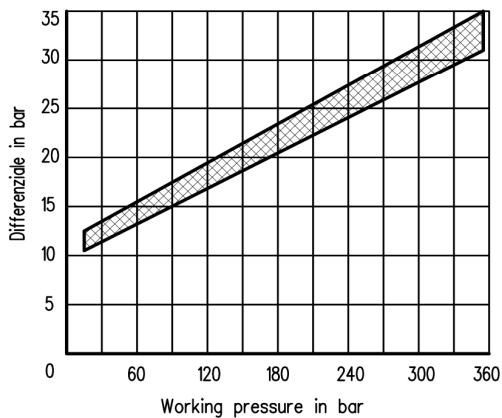

DIFFERENTIAL PRESSURE OF IP-630 PRESSURE SWITCH

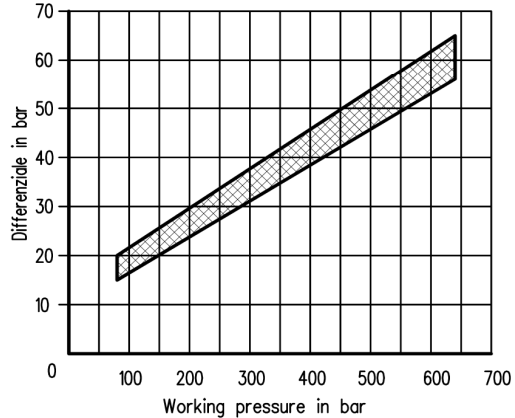



## Adaptors

**SBM-03/210-IP-\*\***

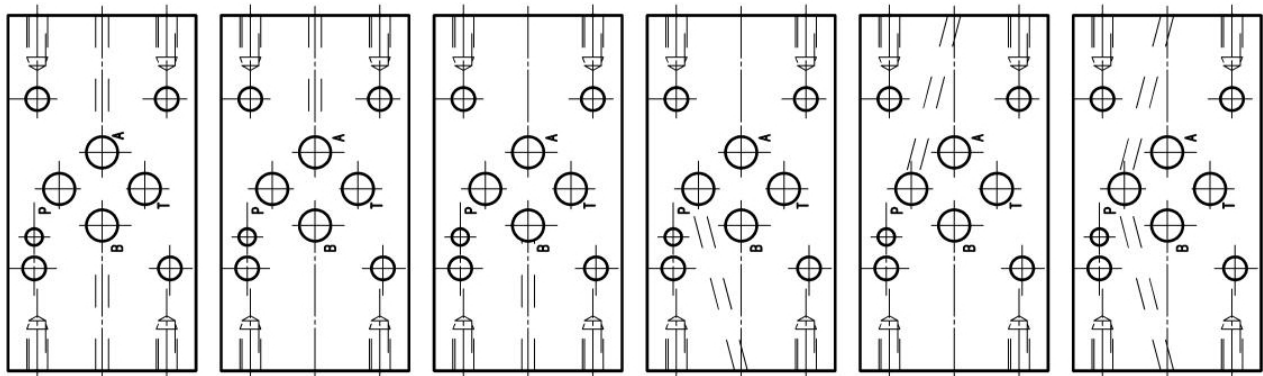

Version AB

Version A

Version B

Version P1

Version P2

Version PP

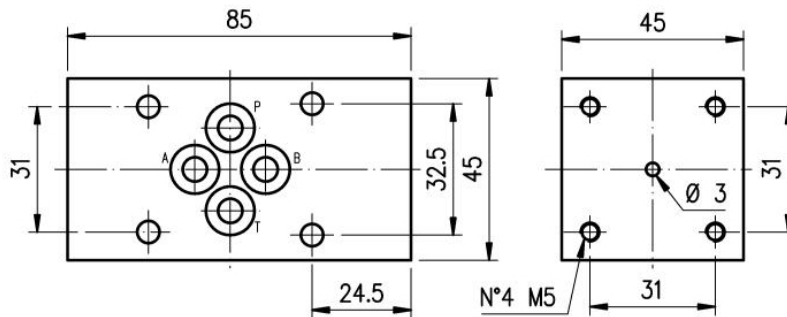

When your order, replace the asterisks with the port/ports on which the device will be mounted.  
Es. **SBM-03/210-IP-B** = Pressure switch operating on B port.

**SBM-05/210-IP-\*\***

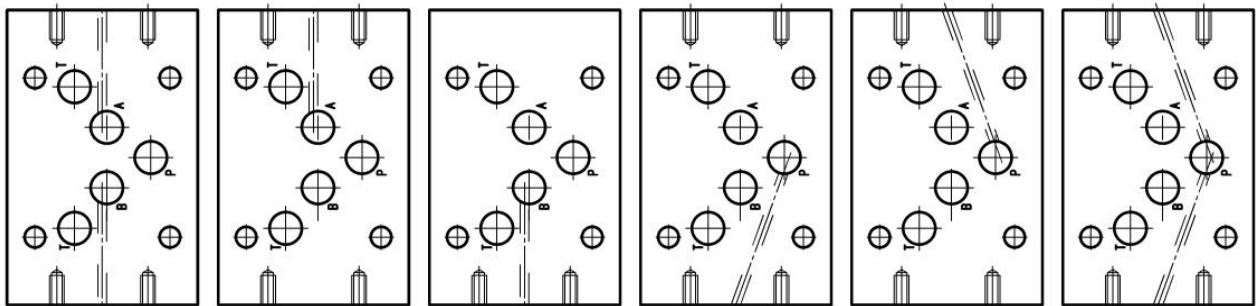

Version AB

Version A

Version B

Version P1

Version P2

Version PP

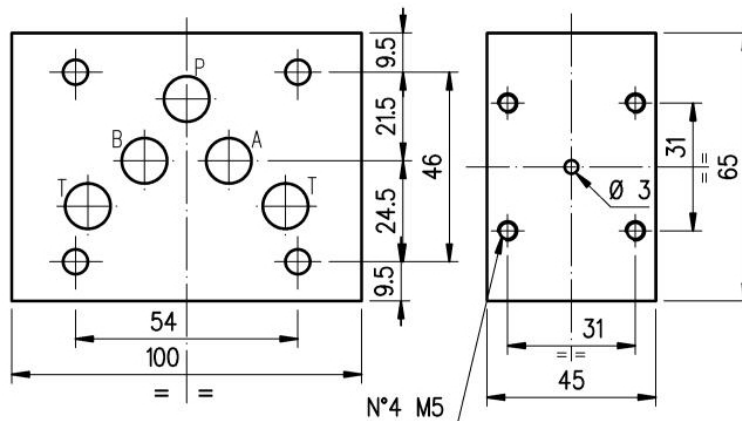

When your order, replace the asterisks with the port/ports on which the device will be mounted.  
Es. **SBM-05/210-IP-B** = Pressure switches operating on B port.

# PISTON PRESSURE SWITCH type IP



## BFU-14 (Female adaptor)

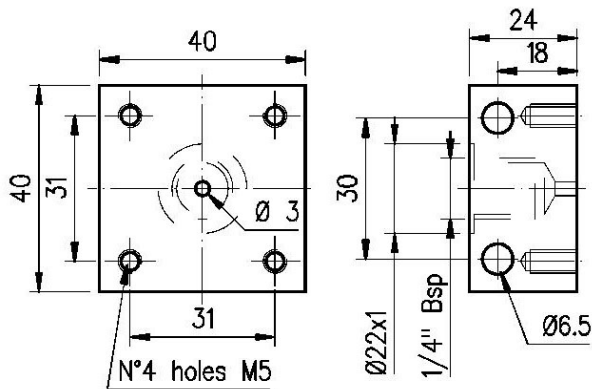

**WEIGHT** 0.3 Kg.

## BMM-\*\*

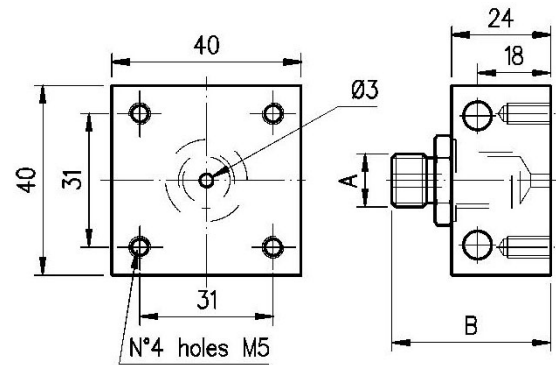

TYPE	A	B
BMM-14	1/4" BSP	41
BMM-38	3/8" BSP	45
BMM-12	1/2" BSP	46

**WEIGHT** 0.3 Kg.

## BFM-\*\*

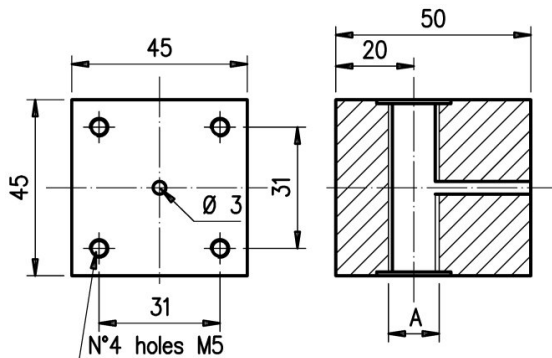

TYPE	A
BFM-14	1/4" BSP
BFM-38	3/8" BSP
BFM-12	1/2" BSP

**WEIGHT** 0.6 Kg.

## BT-1/4x8

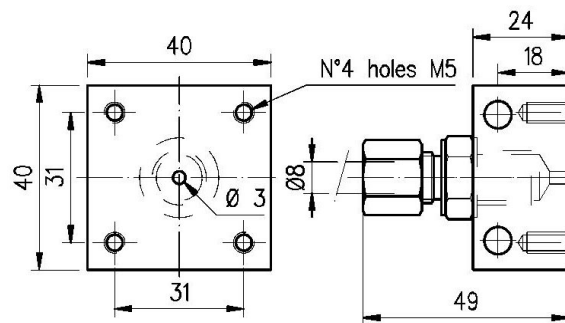

It allows the pressure switch mounting:  
 - wall-type by using 2  $\varnothing 6.5$  holes  
 - equipped with 1/4" BSP tang for  $\varnothing 8$  hose

## Installation rules

- The pressure switches type IP can be mounted in any position
- Fluid to be used: hydraulic oil in compliance with DIN 51524 rules, viscosity between 30 and 100 mm<sup>2</sup>/s (cSt) at 40°C
- Recommended filtration of 25 $\mu$
- Hydraulic fluid temperature: from -20° to +75°C

## Ordering code

IP - \*\*\* / \*

/A = electric contacts type A /E = electric contacts type E

Pressure setting : 035=6-35 bar 150=12-150 bar 250=12-150 bar 350=30-350 bar 630=50-630 bar

Pressure switch

The product has not to be used as safety device as stated in Article 1, paragraph 2, letter D of Legislative Decree N° 93 dated 25/02/2000.

The component has been designed and manufactured meeting the requirements stated in Directive 97/23/CE ( Legislative Decree N° 93/00 ).

The component is included in the category provided in Article 3, paragraph 3, for which it can be commercialized without CE marking.