

FILLING AND CHECK VALVE



Filling valves characteristics

TYPE	Size	Max.Flow (l/min.)	Max. Press.	Opening ratio	Decompr. ratio	Min pilot pressure	Max pilot pressure	Min. suction opening pressure	Pilot volume (cm ³)	Weight (Kg)
R-114	DN-32	160 l/min.	400 bar	3.6:1	1:5	8 bar	100 bar	0.12 bar ±10%	1.22	1.2
R-112	DN-40	250 l/min.		3.9:1					2.36	1.7
R-200	DN-50	400 l/min.		4.2:1					4.91	2.5
R-212	DN-63	600 l/min.		4.5:1					8.13	3.5
R-300	DN-80	1000 l/min.		12.72					5.2	
R-400	DN-100	1600 l/min.		28.63					12	
R-500	DN-125	2500 l/min.		67.86					20	
R-600	DN-160	4000 l/min.	142.39	42						
R-800	DN-200	7000 l/min.	350 bar	4.0:1	-				235.62	116
R-800H									102	
R-900H	DN-250	10000 l/min.							475.17	230

Please note that the given flow values have been obtained with oil viscosity 40 (cSt) at 50°C

Description

These valves allow the quick pre-filling and discharging of cylinders in compression presses. They are available with or without pre-opening device. The conical seat of the obturator allows the perfect sealing. The valves opening, through PP piloting, must be performed only after the cylinder pressure has been discharged.

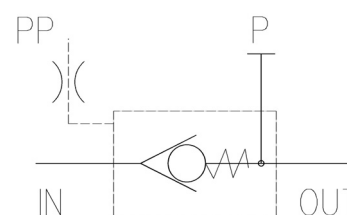

PP Pilot port
P Auxiliary pressure port
IN Tank side
OUT Cylinder side

Check valves characteristics

TYPE	Size	Max. flow	Max. Pressure	Min. suction opening pressure	Weight (Kg)
RR-114	DN-32	160 l/min.	400 bar	0.12 bar ±10%	1
RR-112	DN-40	250 l/min.			1.5
RR-200	DN-50	400 l/min.			2
RR-212	DN-63	600 l/min.			3
RR-300	DN-80	1000 l/min.			4.5
RR-400	DN-100	1600 l/min.			10
RR-500	DN-125	2500 l/min.			16
RR-600	DN-160	4000 l/min.	33.5		
RR-800	DN-200	7000 l/min.	350 bar		102
RR-800H					95
RR-900H	DN-250	10000 l/min.			210

Description

The check valves allow the flow in one direction and prevent it in the opposite one. The mounting is in line by means of suitable flanges according to DIN norms.

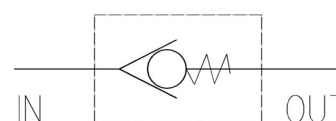

IN Tank side
OUT Cylinder side

FILLING AND CHECK VALVE



Filling valves

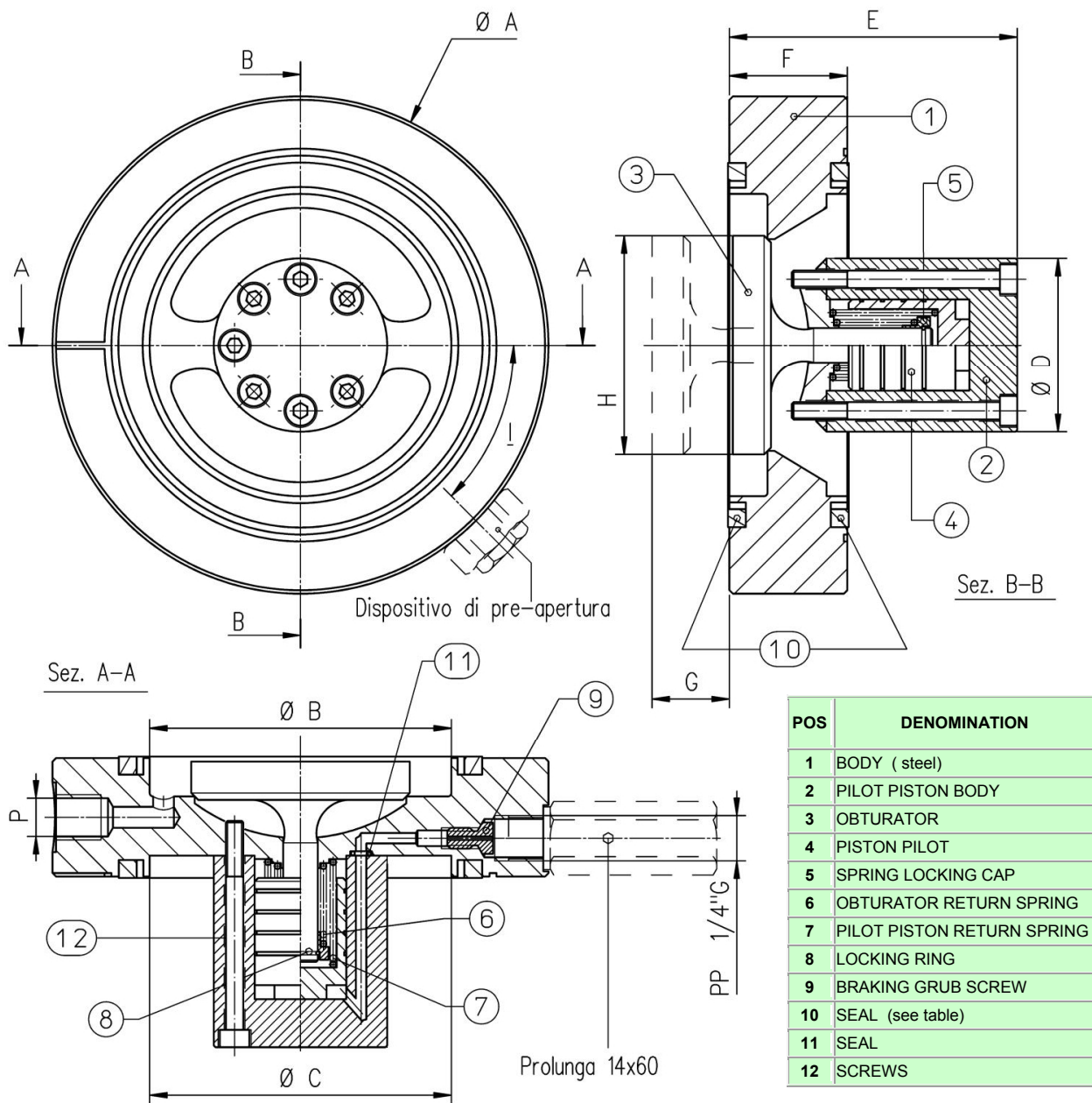

TYPE	A	B	C	D	E	F	G	H	I	P (Bsp)
R-114	93	43	43	32	55	27	8.2	32	60°	1/4
R-112	108	58	58	39	60	28	8.9	41.5	45°	1/4
R-200	128	73	73	45	72	29	12.9	53	45°	1/4
R-212	143	87	87	50	83	34	13.4	63	45°	1/4
R-300	169	107	107	56	98	38.5	17.8	80	45°	1/4
R-400	212	130	130	70	118	44	23.4	100	45°	3/8
R-500	248	168	151	88	154	51	27.4	127	-	3/8

Extension for piloting port is included in sizes **R114 ÷ R500** (to be ordered separately for R600 and R800 , R800H,R900)



Filling valves

TYPE

R-600

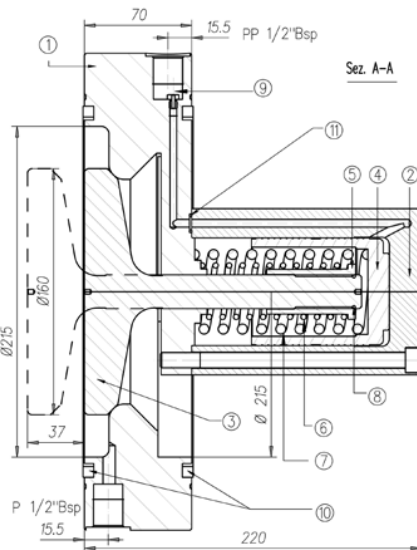
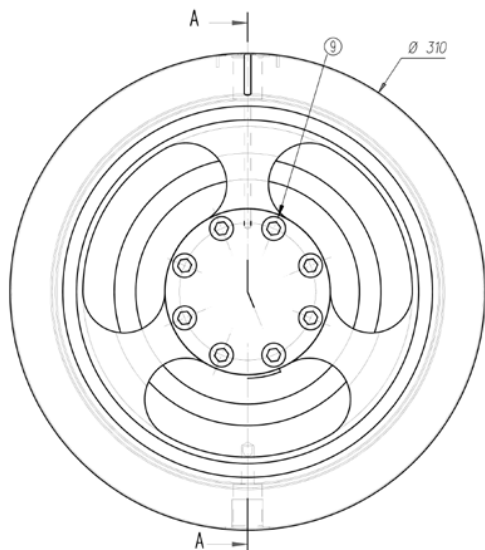

POS	DENOMINATION
1	BODY (steel)
2	PILOT PISTON BODY
3	OBTURATOR
4	PISTON PILOT
5	SPRING LOCKING CAP
6	OBTURATOR RETURN SPRING
7	PILOT PISTON RETURN SPRING
8	LOCKING RING
9	BRAKING GRUB SCREW
10	SEAL (see table)
11	SEAL
12	SCREWS

TYPE

R-800

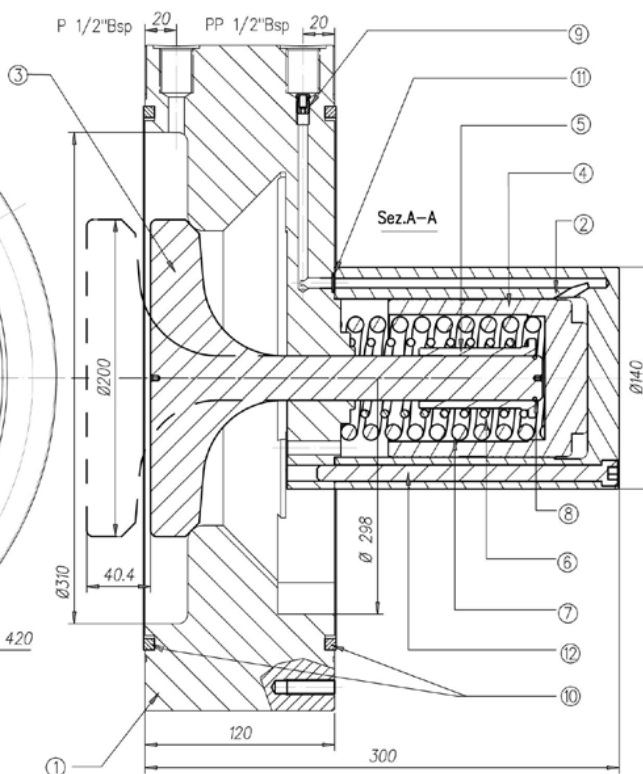
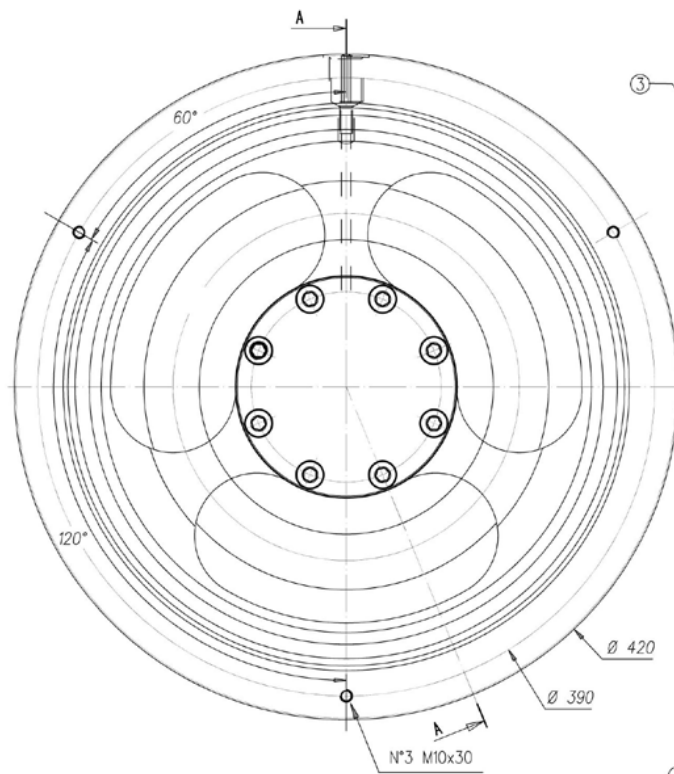

* See ordering code page 10



Check valves

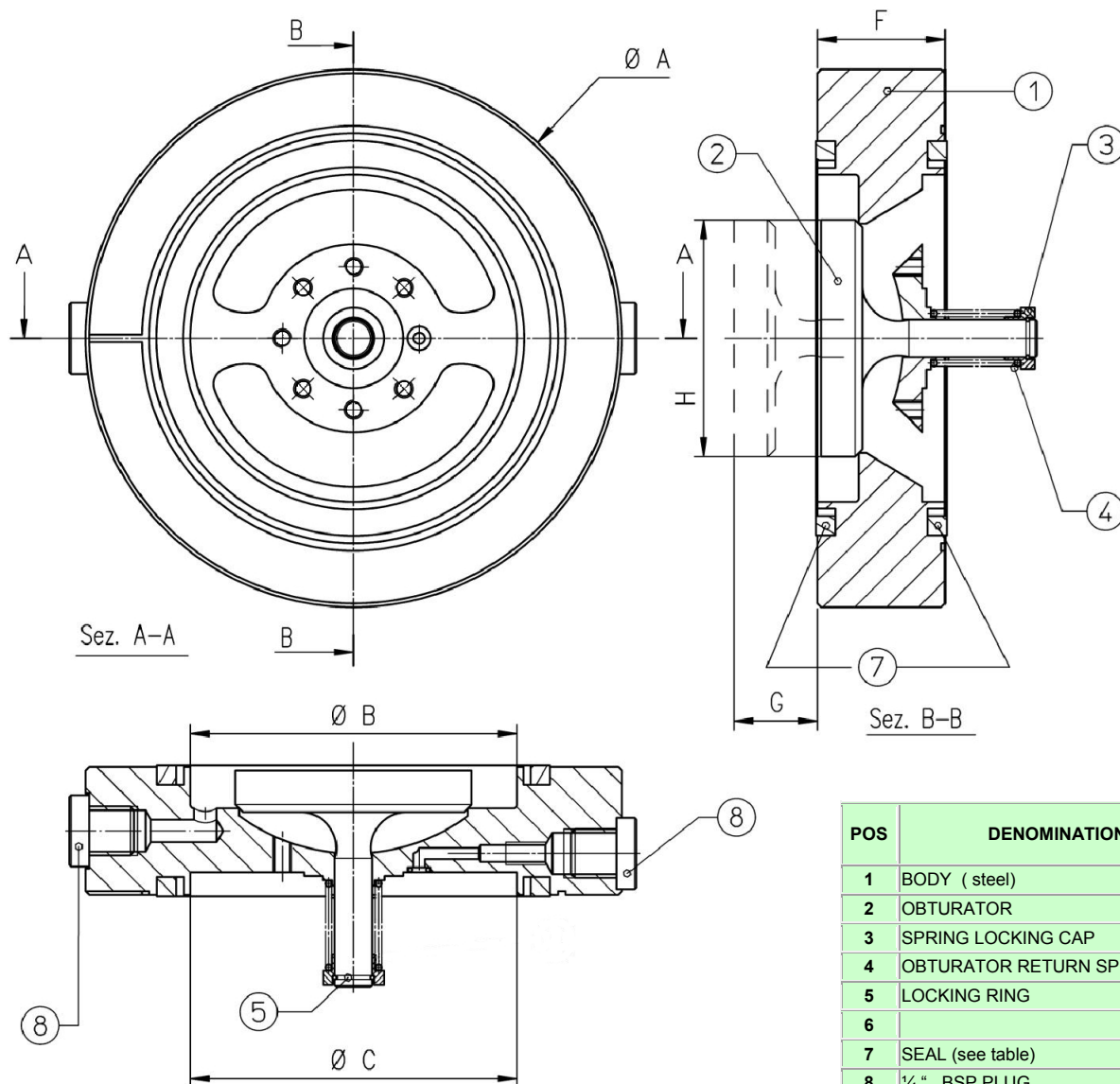

POS	DENOMINATION
1	BODY (steel)
2	OBTURATOR
3	SPRING LOCKING CAP
4	OBTURATOR RETURN SPRING
5	LOCKING RING
6	
7	SEAL (see table)
8	1/4" BSP PLUG

TYPE	A	B	C	F	G	H
RR-114/*	93	43	43	27	8.2	32
RR-112/*	108	58	58	28	8.9	41.5
RR-200/*	128	73	73	29	12.9	53
RR-212/*	143	87	87	34	13.4	63
RR-300/*	169	107	107	38.5	17.8	88
RR-400/*	212	130	130	44	23.4	100
RR-500/*	248	168	151	51	27.4	127

* See ordering code page 10

FILLING AND CHECK VALVE



Check valves

TYPE
RR-600

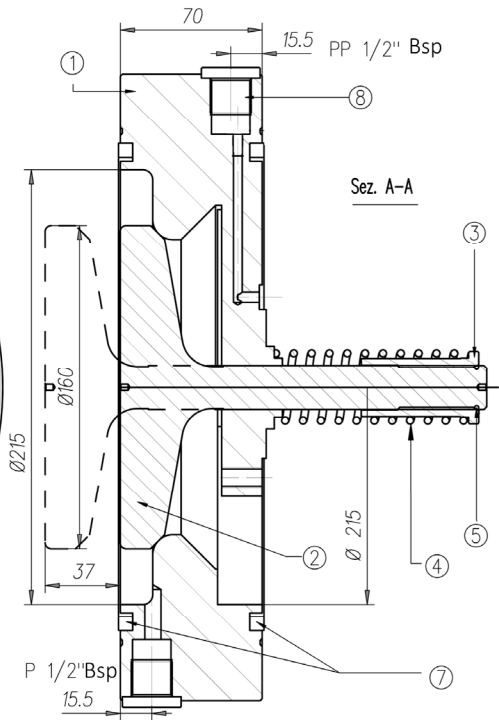
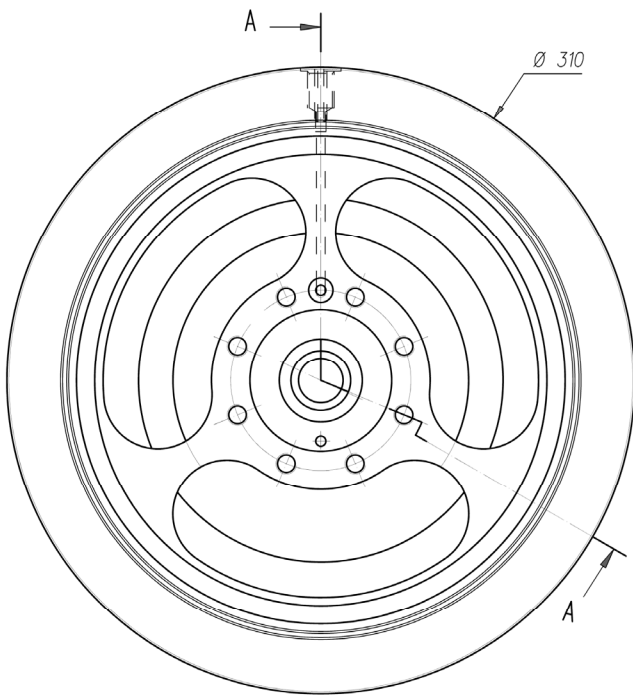

POS	DENOMINATION
1	BODY (steel)
2	OBTURATOR
3	SPRING LOCKING CAP
4	OBTURATOR RETURN SPRING
5	LOCKING RING
6	
7	SEAL (see table)
8	1/2 " BSP PLUG

TYPE
RR-800

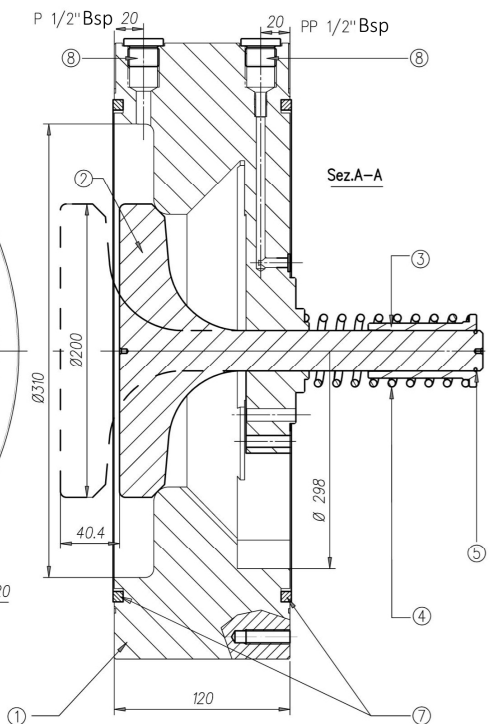
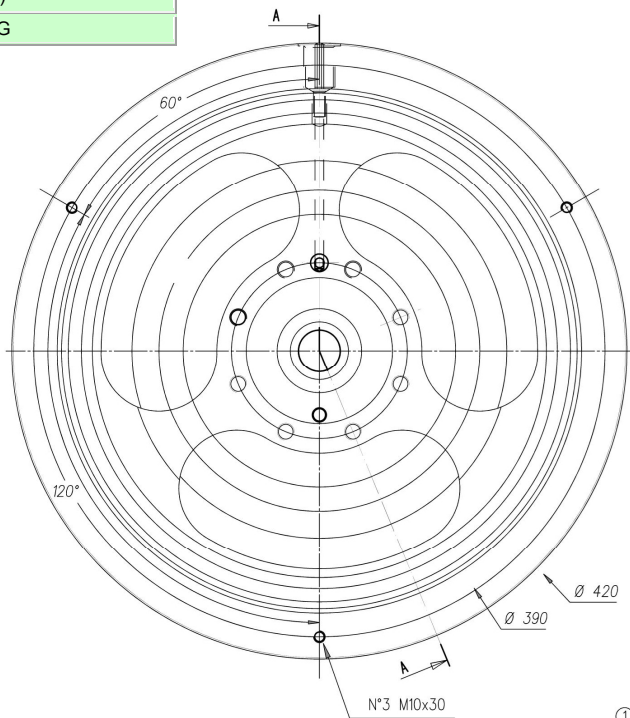

* See ordering code page 10



Check valves

TYPE
RR-800H

POS	DENOMINATION
1	BODY (steel)
2	OBTURATOR
3	SPRING LOCKING CAP
4	OBTURATOR RETURN SPRING
5	LOCKING RING
6	BRAKING GRUB SCREW
7	SEAL (see table)
8	1/2 " BSP PLUG

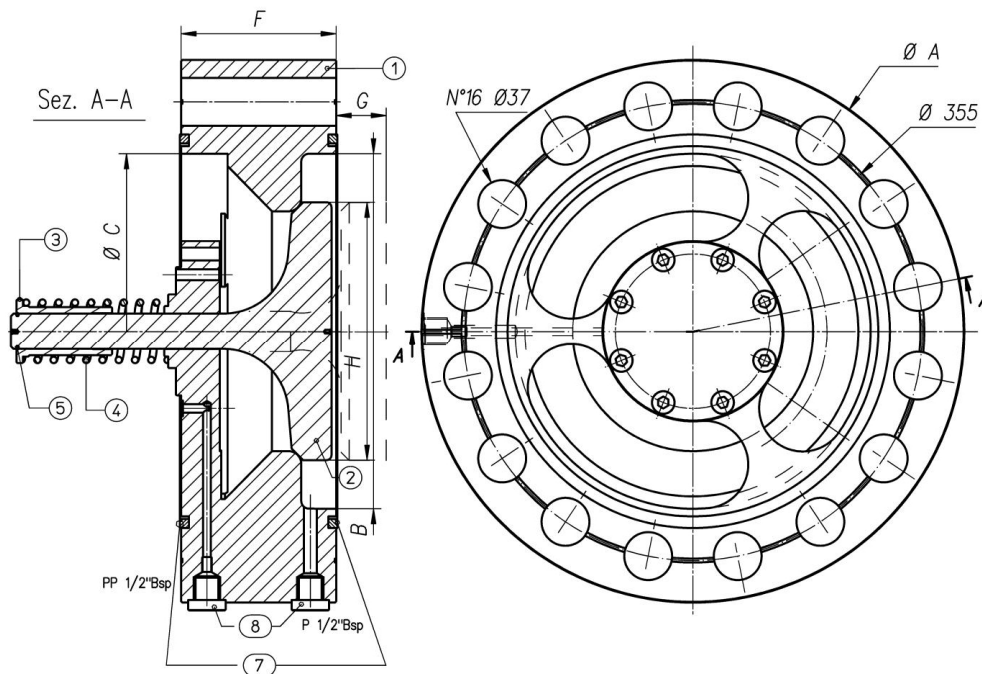

Filling valves

TYPE
R-800H

POS	DENOMINATION
1	BODY (steel)
2	PILOT PISTON BODY
3	OBTURATOR
4	PISTON PILOT
5	SPRING LOCKING CAP
6	OBTURATOR RETURN SPRING
7	PILOT PISTON RETURN SPRING
8	LOCKING RING
9	BRAKING GRUB SCREW
10	SEAL (see table)
11	SEAL
12	SCREWS

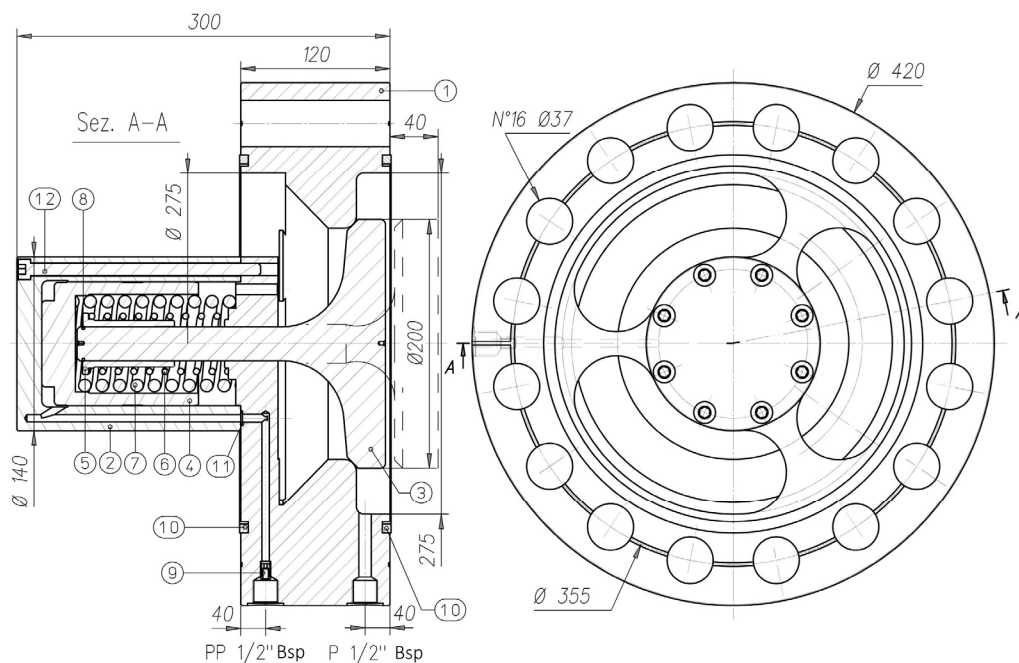

* See ordering code page 10

FILLING AND CHECK VALVE



Filling valves

TYPE
R-900H

POS	DENOMINATION
1	BODY (steel)
2	PILOT PISTON BODY
3	OBTURATOR
4	PISTON PILOT
5	SPRING LOCKING CAP
6	OBTURATOR RETURN SPRING
7	PILOT PISTON RETURN SPRING
8	LOCKING RING
9	BRAKING GRUB SCREW
10	SEAL (see table)
11	SEAL
12	SCREWS

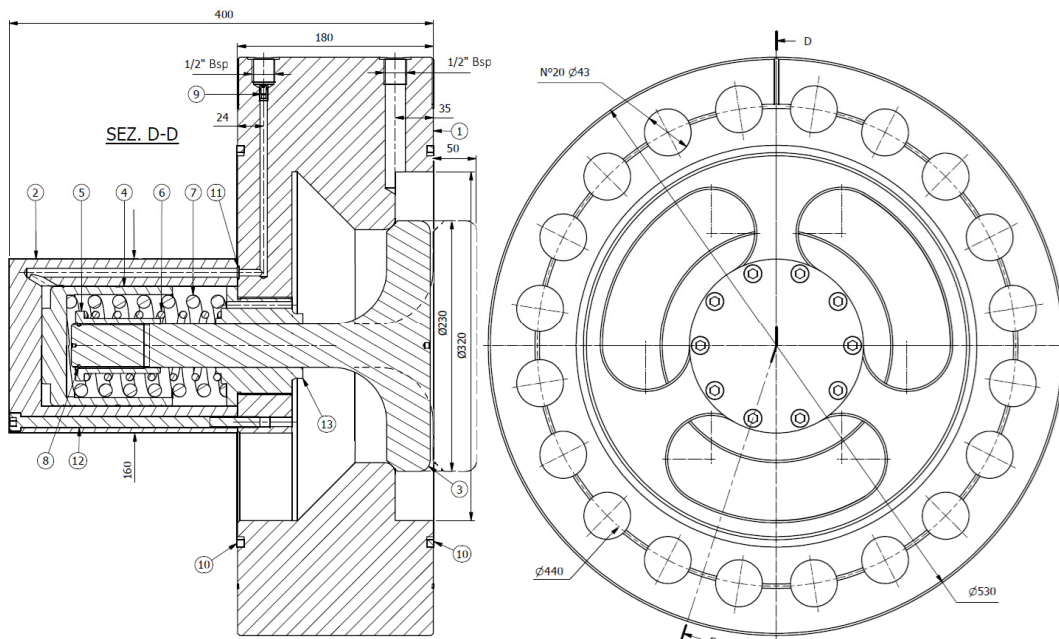

Filling valves

TYPE
RR-900

POS	DENOMINATION
1	BODY (steel)
2	OBTURATOR
3	SPRING LOCKING CAP
4	OBTURATOR RETURN SPRING
5	LOCKING RING
6	
7	SEAL (see table)
8	1/2 " BSP PLUG

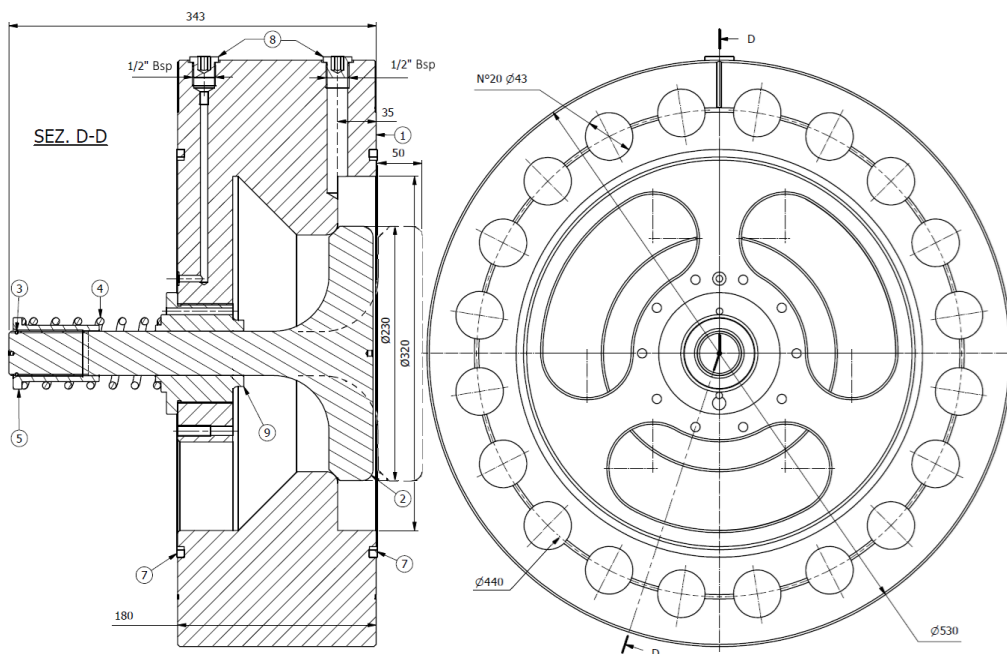

* See ordering code page 10

FILLING AND CHECK VALVE



Flanges dimensions

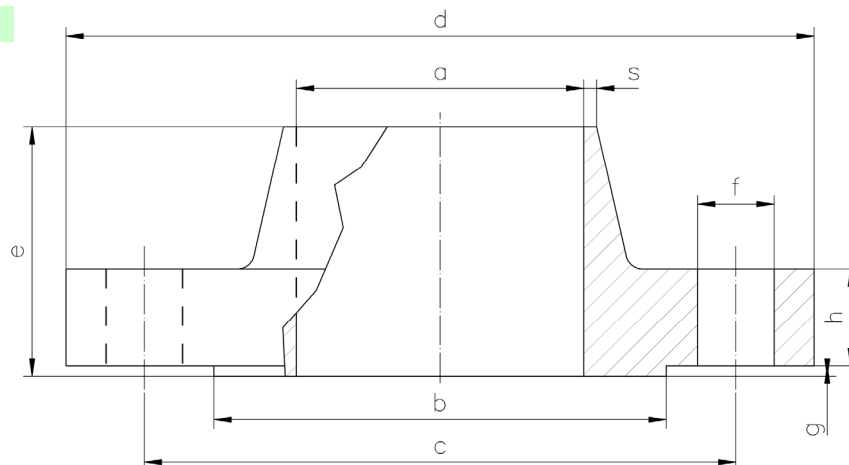

TIPO	UNI	DIN	DN	a	b	c	d	e	f	g	h	S
FL-R114	2284	2635	40	43.5	88	110	150	43	18	2.5	15	3.5
FL-R112	2285	2636	50	54.5	95	135	180	62	22	2.5	23	3.5
FL-R200	2285	2636	65	70	120	160	205	68	22	2.5	23	3.5
FL-R212	2285	2636	80	83	130	170	215	72	22	2.5	25	3.7
FL-R300	2285	2636	100	107.5	160	200	250	78	25	2.5	27	4
FL-R400	2286	2637	125	127.4	185	250	315	105	33	2.5	37	6.8
FL-R500	2286	2637	150	154.5	215	290	355	115	33	3	41	8

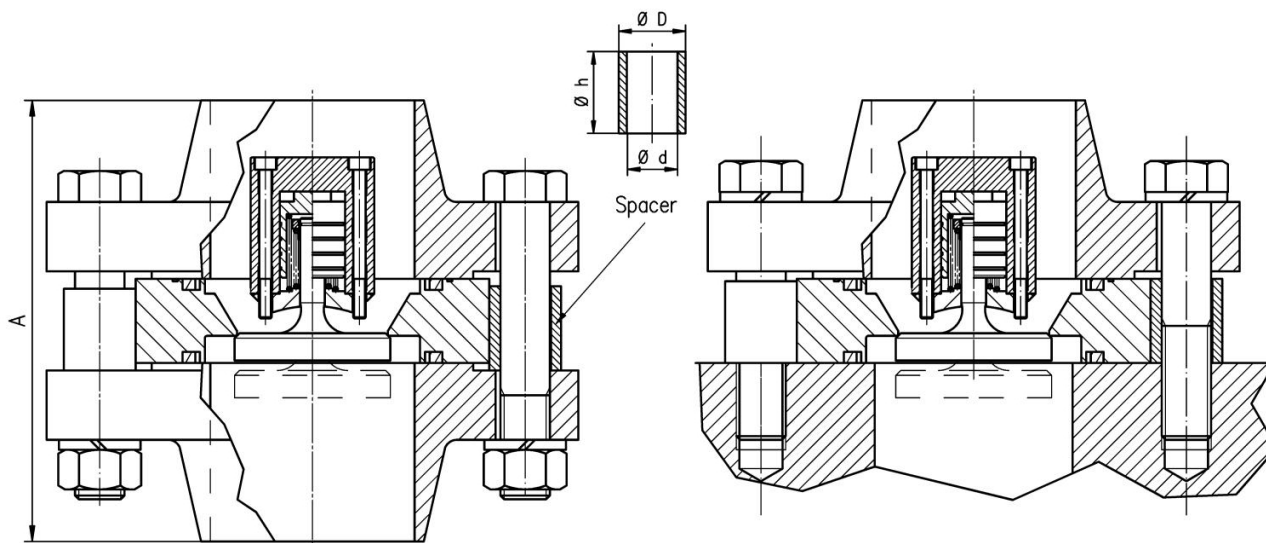

TYPE	A	1 flange Screw set	2 flanges Screw set	N° of screws	Ø d	Ø D	h	LOCKING TORQUE (kgm)	
R-114/*	117	M16 x 70	M16 x 80	4	-	-	-	21	
R-112/*	152	M20 x 90	M20 x 110				27	30	
R-200/*	165	M20 x 90	M20 x 110	8	20.5	32	28	38	
R-212/*	178	M20 x 90	M20 x 120			27	41		
R-300/*	195	M24 x 100	M24 x 130			24.5	31	38	70
R-400/*	254	M30 x 130	M30 x 160			30.5	38	43	110
R-500/*	281	M30 x 140	M30 x 160	12	30.5	41.5	50	130	

* See ordering code page 10



Differential pressure in suction and filling in relation to the flow

Values on diagrams refer to a valve assembled under the tank.

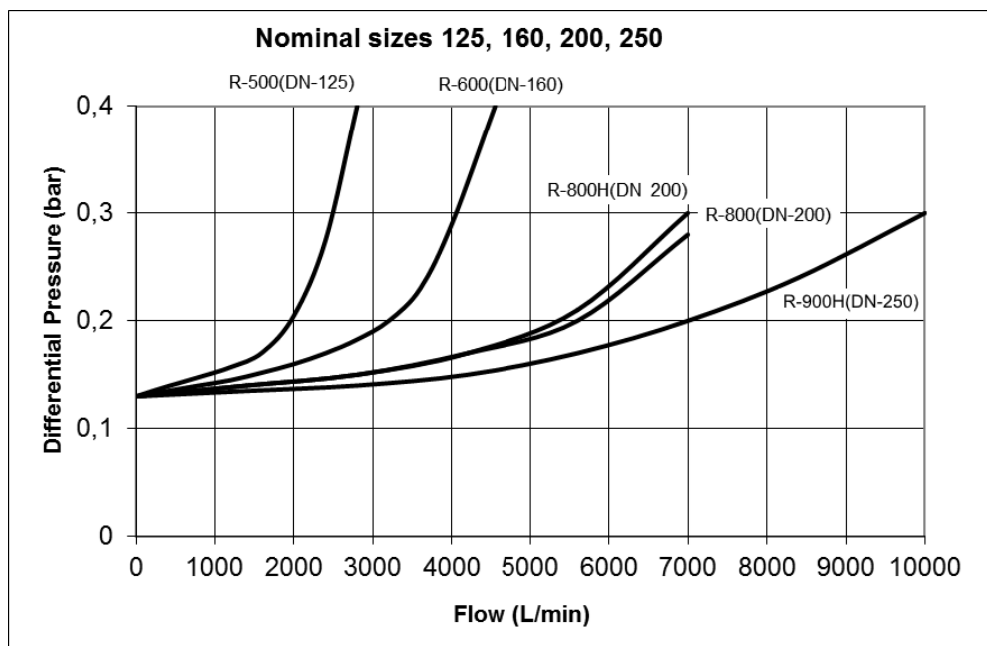
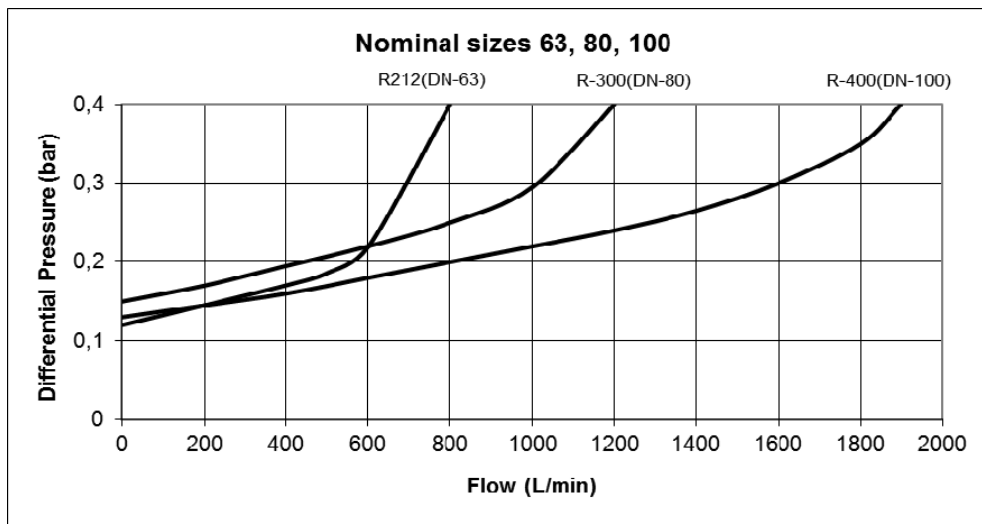
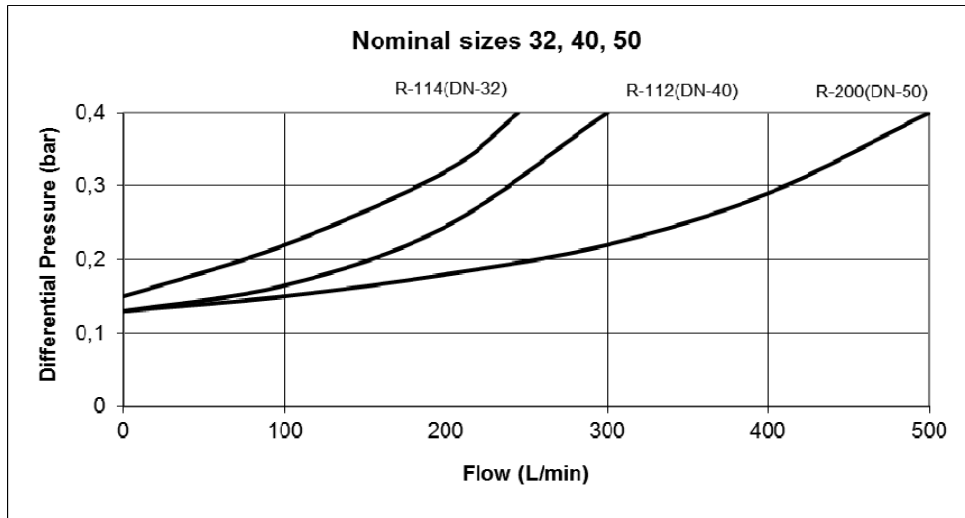



Seals

SEAL x R***				
Model	KANTSEAL Square Ring	∅ A H11	B ^{+0,2}	C ^{-0,05}
R-114	DKAR00227-N90	60,3	4,8	3,1
R-112	DKAR00231-N90	73	4,8	3,1
R-200	DKAR00236-N90	88,9	4,8	3,1
R-212	DKAR00343-N90	104,8	7,1	4,75
R-300	DKAR00350-N90	127	7,1	4,75
R-400	DKAR00433-N90	152,4	9,5	6,1
R-500	DKAR00442-N90	196,9	9,5	6,1
R-600	DKAR00447-N70	241,3	9	6,1
R-800	DKAR00455-N70	342,9	9	6,1
R-800H	DKAR00452-N70	304,8	9	6,1
R-900H	DKAR00457-N90	368,3	9,5	6,1

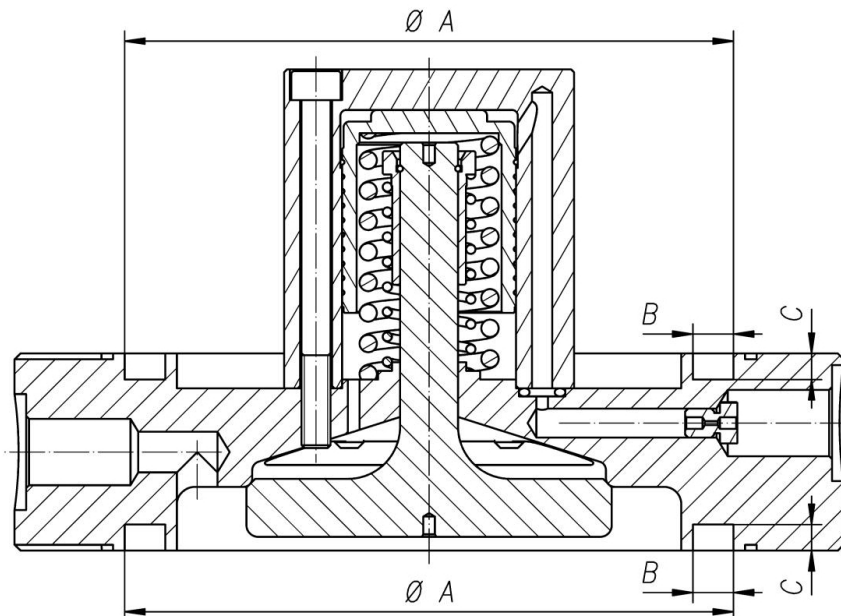

Installation rules

- For sizes up to 212, the assembly can be made either vertical or horizontal. For bigger sizes the vertical assembly is compulsory.
- Fluid to be used: hydraulic oil in compliance with DIN 51524 rules, viscosity between 30 and 100 mm²/s (cSt) at 40°C
- Recommended filtration of 25µ.
- Hydraulic fluid temperature: from -20° to +75°C

Ordering code

** - *** H / ** - **

1FL= Equipped with 1 flange 2FL= Equipped with 2 flanges (on request, only for sizes from 114 to 500)

PA (only for R) = Equipped with pre-opening device (on request, only for sizes from 114 to 400)

H = Fixing holes in the body version (DN-200 - DN-250 only)

Size 114 ÷ 900

R = Quick filling and discharging valve RR = Check valve